

LR02-IS. ATEX APPROVED ZONES 1 & 2 **NON MERCURY LEVEL REGULATORS**

Float Switches are inexpensive and efficient liquid level detectors, simple to install, designed for trouble free operation over a long life.

The **LR02-IS** is a variant of the **LR-02** series, contains a special **low voltage/low current** microswitch that is compatible with the voltage and current requirements of intrinsically safe systems.

Construction

The unit comprises three major components :

1. The float chamber houses the microswitch arrangement, totally sealed within closed cell polyurethane foam, with a single pole double throw action. Outer walls of the switch are moulded in *Hypalon*, CSP Synthetic rubber.
2. The three-cored cable, connected to the microswitch assembly inside the float chamber, is sheathed in CPE synthetic rubber. This cable is supplied in three standard lengths, 5 metres, 10 metres and 20 metres $\pm 5\%$ of the length quoted.
3. A stabilizing weight fixed to the cable approximately 120 mm from the float chamber is also coated in *Hypalon*.

Hypalon Du Pont de Nemours, Wilmington, Delaware.

Mounting

There are no hard and fast rules applicable to mounting these units, however the lead should be supported in an enclosed vessel, and in an open vessel it is advantageous to clip the lead to the side especially if excessive turbulence is experienced.

To obviate the effects of rapid switching conditions that would result if such turbulence is experienced, it is advantageous to use a maintaining circuit which both safeguards the microswitch and cuts out any chatter of the starters of associated pumps etc.

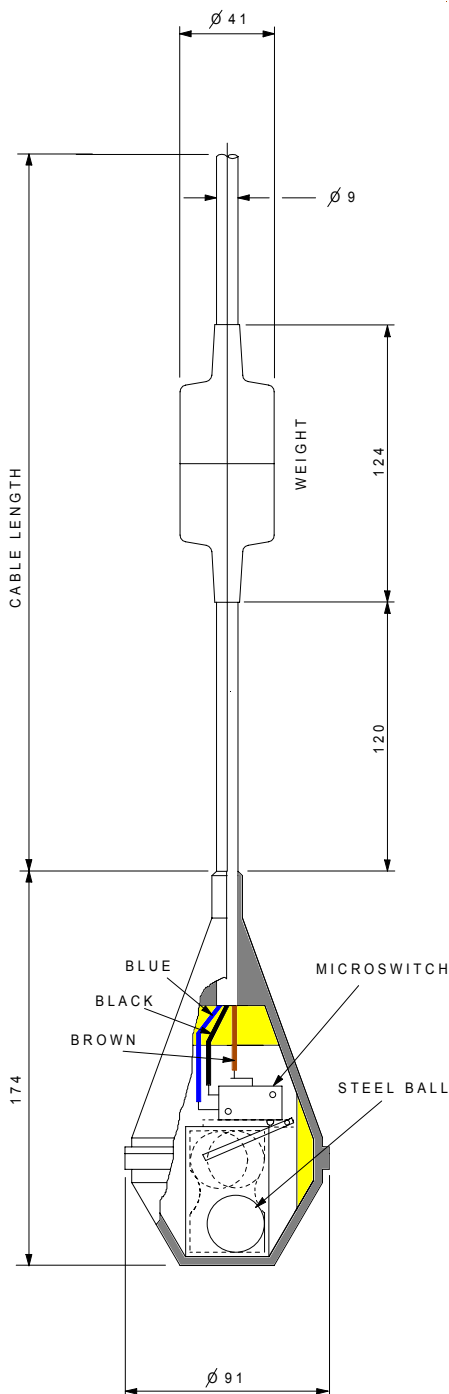

LR02-IS. NON MERCURY FLOAT SWITCH

Method of Operation

The microswitch assembly inside the float, axially mounted in line with the weight, changes contacts according to the float's position, as in the diagram below. Therefore as the liquid level drops or rises slowly, a pump or flow control suitably connected, can be switched in or out to maintain an average level of the liquid. By connecting only one side of the switch, the unit can be also used to fill or empty the tank as required.

Dimensions, in mm, do not take into consideration any lateral swing of the cable.

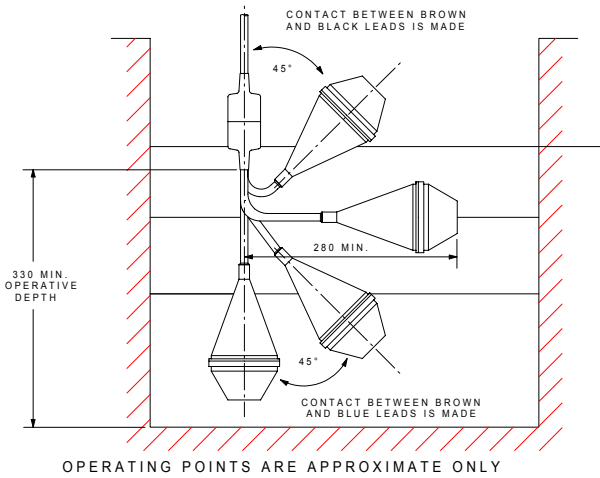

Float Switch series LR02-IS is subject to the limitations contained within the Product Approval:

Ex II 2G, EEx ia IIC T6
Ambient temperature -20 to +70°C

Type LR02-IS (Certificate SIRA 04ATEX2187) may be used in zones 1 and 2 with flammable gases and vapours with apparatus groups IIA, IIB, & IIC and with temperature classes T1, T2, T3, T4, T5 & T6.

The equipment is certified for use in ambient temperature range -20°C to +70C and should not be used outside this range.

Specification

**Max Input Parameters: $U_i = 30V$, $I_i = 100mA$
8v, 8mA dc minimum contact rating
suitable for IS system inter-face**

Max. temperature 70° C
Max. submerged depth 20 metres
Compressive Strength 482 KN/m² (70 lbf/in²)
Operational in specific gravities from 0.8 to 1.3

Chemical Resistance

Against	Rating
Lubricants	Fair
Diesel oil & petrol	Poor
Vegetable & animal fats	Good
Water Absorption	Good
Oxidation	Good
Ozone	Good
Sunlight	Good
Dilute Acids	Good
Alkalis	Good
Alcohols	Good
Salt water	Good

When ordering please specify part numbers.

Type	Part Number	Weight (approx)
5 metre cable	LR02IS-L05M	1.3 Kg
10 metre cable	LR02IS-L10M	1.8 Kg
20 metre cable	LR02IS-L20M	2.8 Kg

